

RESPONSIVE 



IMPACT
A BETTER FLOOR

IMPACT LVP 2.0

LUXURY VINYL PLANK | 2.0 MM



SIZE: 7.25" x 48"

THICKNESS: 2.0 MM

WEAR LAYER: 12 MIL | 0.30 MM

PIECES: 20 PER CARTON

COVERAGE: 48.33 SF / CARTON | 4.49 M2 / CARTON

INSTALLATION: DRY BACK, GLUE DOWN LVP

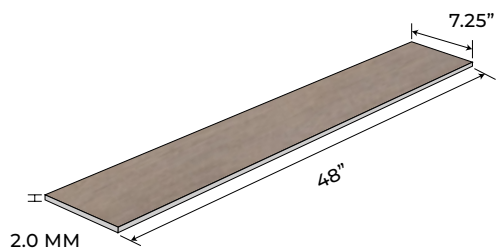

7.25" x 48" x 2.0 mm
185 mm x 1219 mm x 2.0 mm
12 MIL / 0.30 mm

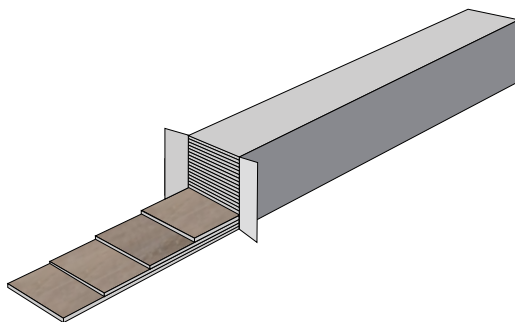

20 PCS / CARTON
48.33 SQ.FT / CARTON
4.49 SQ.M / CARTON

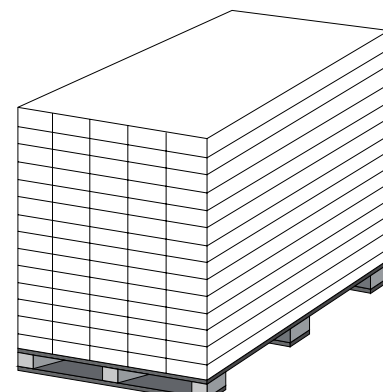

70 CARTONS / PALLET

Luxury Vinyl Planks For Light To Heavy Commercial | PUR Polyurethane Reinforcement | Product Standard: ISO 10582

CERTIFICATION & CLASSIFICATION	STANDARD	IMPACT LVP 2.0
TYPE OF FLOOR COVERING	ISO 10582	LUXURY VINYL PLANK
CE CERTIFICATION	EN 14041	YES
CLASSIFICATION	EN ISO 10874	HEAVY TRAFFIC: DOMESTIC 23 COMMERCIAL 33

TECHNICAL CHARACTERISTICS	STANDARDS	IMPACT LVP 2.0
TOTAL THICKNESS	EN ISO 2436 (EN 428)	2.0 MM (2.5MM / 3.0MM AVL ON DEMAND)
WEAR LAYER THICKNESS	EN ISO 24340 (EN 429)	0.30 MM (0.50 / 0.70 AVL ON DEMAND)
SURFACE TREATMENT	UV TREATED	PUR
TOTAL WEIGHT	EN ISO 23997 (EN 430)	3300 G/M ²
WEAR LAYER BINDER CONTENT	ISO 10582	TYPE I
FORM OF DELIVERY	EN ISO 24342 (EN 427) Planks box	7.25" X 48" 20 PLANKS / CARTON = 48.33 SF 185 X 1219 MM 20 PLANKS / CARTON = 4.49 M ²

TECHNICAL PERFORMANCES	STANDARDS	IMPACT LVP 2.0
DIMENSIONAL STABILITY	EN ISO 23999 (EN 434)	PASS
REACTION TO FIRE	EN 13501 – 1	<u>B</u> FL- S1 GLUED OVER A2FL SUBSTRATE (CONCRETE)
RESIDUAL INDENTATION	EN ISO 24343-1 (EN 433)	PASS
FURNITURE LEG	EN 424	NO DAMAGE
CASTOR CHAIR	EN ISO 4918 (EN 425)	NO DAMAGE
CURL RESULTANT TO HEAT	EN ISO 23999 (434)	PASS
THERMAL RESISTANCE	EN ISO 10456	0.07 M2 K/W
LIGHT FASTNESS	EN ISO 105 – B02	>GRADE 6 PASS
RESISTANCE TO CHEMICALS	EN ISO 26987 (EN423)	GOOD RESISTANCE PASS
SLIP RESISTANCE	DIN51130 EN 13893	R9 CLASS DS
ELECTRICAL PROPERTIES	EN 1815 EN 1081	<2KVONCONCRETE R1 > 10 ¹⁰ Ω



ISO 9001
ISO 14001
ISO 18001



LIMITED RESIDENTIAL WARRANTY



LIGHT COMMERCIAL WARRANTY

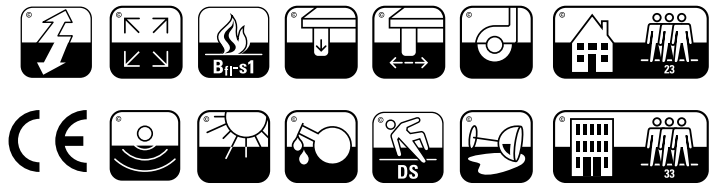

EN 14041

UV SURFACE TREATMENT: Thickness In Microns

- Transparent PVC Wear Layer 0.3m
- Super Stain And Scratch Resistant
- Completely Waterproof
- Protects From Abrasion

DECORATIVE FILM

- Restores The Color And Emboss
- Elegant Wood Designs
- Natural Looking & Natural Feeling

OVER ALL THICKNESS: 2.0 mm



FIBER GLASS LAYER

- Provides Dimensional Stability
- Ensures Flat & Even Installation

1mm PVC BACKING LAYER

- Insulates Sound
- Provides Underfoot Comfort
- No Bugs, No Termites

FEATURES & BENEFITS



Superior Scratch & Stain Resistant



Zero Maintenance



Easy Clean



Natural Looking Design



Heavy Foot Traffic



Easy Installation

APPLICATIONS



Corporate Offices



Residential



Retail



Hospitality

LIGHT NAVAJO

IMP-OPL-01

RESPONSIVE 

IMPACT
A BETTER FLOOR

LIGHT NAVAJO

IMP-OPL-01

RESPONSIVE



A

B

C

D

E

F

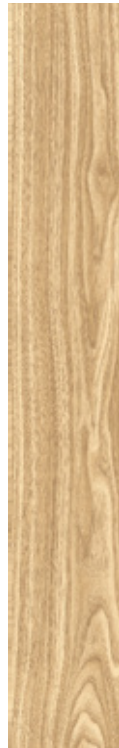
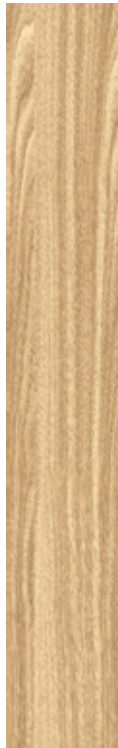
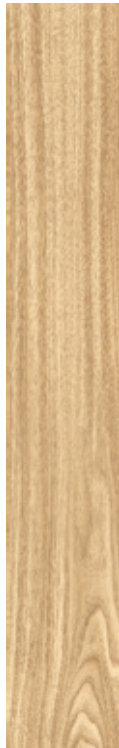

WILD CUMARU

IMP-OPL-04

RESPONSIVE 

IMPACT
A BETTER FLOOR

WILD CUMARU
IMP-OPL-04

RESPONSIVE



A

B

C

D

E

F



PROVINCIAL OAK

IMP-OPL-06

RESPONSIVE 

IMPACT
A BETTER FLOOR

PROVINCIAL OAK

IMP-OPL-06

RESPONSIVE 



A

B

C

D

E

F

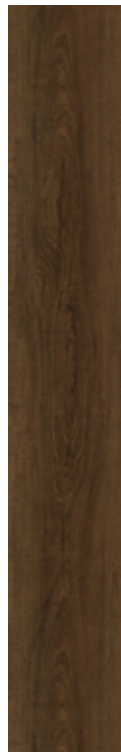
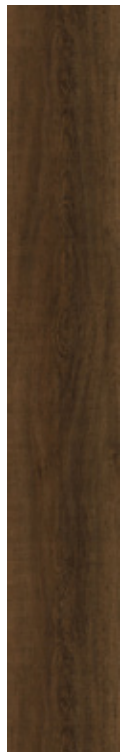
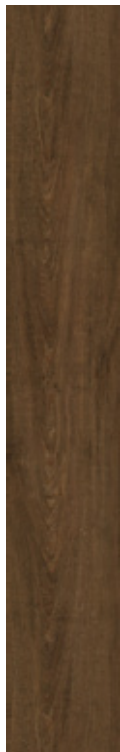
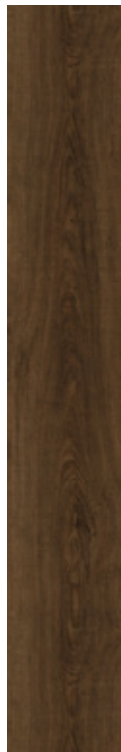
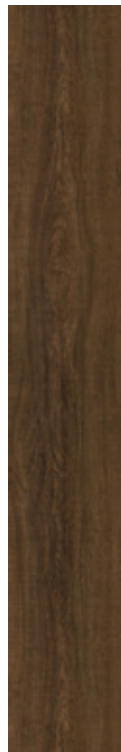

DISTRESSED GREY

IMP-OPL-09

RESPONSIVE 

IMPACT
A BETTER FLOOR

DISTRESSED GREY

IMP-OPL-09

RESPONSIVE



A

B

C

D

E

F

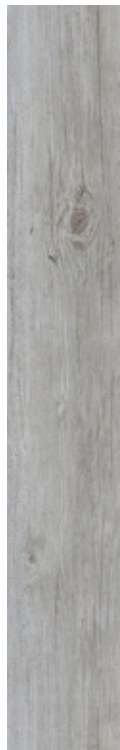
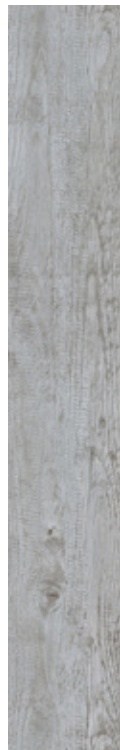

ARTISINAL OAK

IMP-OPL-11

RESPONSIVE 

IMPACT
A BETTER FLOOR

ARTISINAL OAK

IMP-OPL-11

RESPONSIVE



A

B

C

D

E

F

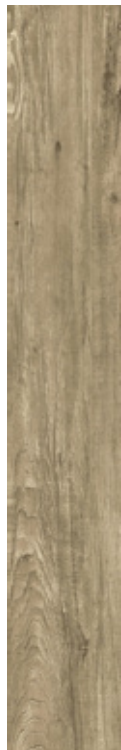
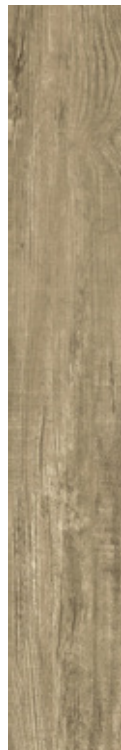

DRIFTWOOD STAIN

IMP-OPL-12

RESPONSIVE 

IMPACT
A BETTER FLOOR

DRIFTWOOD STAIN

IMP-OPL-12

RESPONSIVE 



A



B



C



D



E



F

